



## OPERATING INSTRUCTIONS

# Electronic digital position indicators **DD51-E (GN 9054)\***

\*(Product series valid only for Germany)

# TABLE OF CONTENTS

<b>TABLE OF CONTENTS</b> .....	<b>2</b>
<b>1 SAFETY INSTRUCTIONS</b> .....	<b>3</b>
1.1 CYBERSECURITY .....	4
<b>2 PRODUCT RELEASE INFORMATION</b> .....	<b>5</b>
<b>3 DESCRIPTION</b> .....	<b>5</b>
3.1 WORKING PRINCIPLE.....	5
3.2 “FORMAT CHANGE” USE CASE EXAMPLE .....	6
3.3 “TUBE CUTTING MACHINE” USE CASE EXAMPLE .....	6
<b>4 MECHANICAL AND ELECTRICAL CHARACTERISTICS</b> .....	<b>7</b>
<b>5 INSTALLATION</b> .....	<b>8</b>
<b>6 USER INTERFACE</b> .....	<b>8</b>
6.1 DISPLAY.....	8
6.2 KEYS .....	9
<b>7 QUICK GUIDE</b> .....	<b>11</b>
<b>8 TO SWITCH-ON THE DEVICE (START-UP)</b> .....	<b>11</b>
<b>9 OPERATING MODE</b> .....	<b>12</b>
9.1 UNIT OF MEASURE.....	12
9.2 MEASURE METHOD: ABSOLUTE OR RELATIVE SELECTION .....	13
9.3 DISPLAY RESOLUTION.....	14
9.4 OFFSET SELECTION.....	14
9.5 QUICK ZEROING OF THE INTERNAL REFERENCE POINT .....	14
9.6 QUICK SETTING OF ORIGIN, OFFSET VALUES AND STEP .....	15
<b>10 PROGRAMMING MODE</b> .....	<b>16</b>
10.1 PARAMETERS/MENUS (IN ALPHABETICAL ORDER) .....	17
10.2 MENU TREE.....	20
<b>11 TARGETS MODE</b> .....	<b>22</b>
11.1 CONFIGURE A TARGET MEMORY .....	22
11.2 LOAD (ACTIVATE) A TARGET MEMORY AS TARGET POSITION.....	22
11.3 DISPLAY AND KEY WORKING IN TARGET MODE.....	22
11.4 INDICATIONS FOR REACHING THE TARGET POSITION.....	23
11.5 DISABLING THE TARGET MODE.....	23
<b>12 ADDITIONAL FUNCTIONS</b> .....	<b>24</b>
12.1 ZEROING OF THE INTERNAL REFERENCE POINT .....	24
12.2 RESTORE FACTORY SETTINGS.....	24
12.3 RESTORE FACTORY SETTINGS AND SWITCH-OFF THE DEVICE .....	24
12.4 SWITCHING-OFF THE DEVICE (FOR STORAGE ONLY) .....	24
12.5 LCD TEST .....	24
12.6 KEYS TEST .....	25
12.7 DEVICE INFO.....	25
12.8 PASSWORD: PARAMETERS MODIFICATION LOCKING .....	25
12.9 ECO MODE: AUTO TURN-OFF THE DISPLAY .....	26
12.10 SPEED LIMITS SETTING.....	26
<b>13 BATTERY REPLACEMENT</b> .....	<b>27</b>
<b>14 DISPLAY MESSAGES AND TROUBLESHOOTING</b> .....	<b>28</b>
<b>15 CE DECLARATION OF CONFORMITY (DOC)</b> .....	<b>30</b>
<b>16 UKCA DECLARATION OF CONFORMITY (DOC)</b> .....	<b>31</b>
<b>17 FCC SUPPLIER’S DECLARATION OF CONFORMITY (SDOC)</b> .....	<b>32</b>

# 1 Safety Instructions

This device has been designed and manufactured in accordance with current legislation. To keep the product in this state, it must be assembled and used correctly, in strict compliance with the instructions contained in this instruction manual and with the following specific safety precautions. This manual is intended as an indispensable supplement to the existing documentation (catalogues, data sheets and assembly instructions). Make sure that the user has read and understood the instruction manual and in particular this chapter "Safety instructions". In addition to the instruction manual, all legal regulations regarding accident prevention and environmental protection must be observed. This device complies with Part 15 of the FCC Rules. Operation is subject to the following two conditions: (1) this device may not cause harmful interference, and (2) this device must accept any interference received, including interference that may cause undesired operation. This equipment has been tested and found to comply with the limits for a Class A digital device, pursuant to part 15 of the FCC Rules. These limits are designed to provide reasonable protection against harmful interference when the equipment is operated in a commercial environment. This equipment generates, uses, and can radiate radio frequency energy and, if not installed and used in accordance with the instruction manual, may cause harmful interference to radio communications. Operation of this equipment in a residential area is likely to cause harmful interference in which case the user will be required to correct the interference at his own expense.



Using without respecting the specific descriptions/parameters, in combination with systems/machines/processes to be controlled, can lead to product malfunction, which causes:

- health hazards,
- environmental hazards,
- damage to the product and to its proper functionality.

The device must not be used:

- in explosion hazard areas.
- in medical/life support areas and equipment.

Do not open the equipment and do not apply any modifications!

Modification of the equipment could adversely affect the reliability of the device and could lead to hazards! Do not attempt any repairs. Always return any defective equipment to the manufacturer! Any breach of the integrity of the device as delivered will invalidate the warranty. Changes or modifications not expressly approved by the manufacturer could void the user's authority to operate the equipment.

If the equipment is used in a manner not specified by the manufacturer, the protection provided by the equipment may be impaired.

## Transport and storage

Handle, transport and store the device with care. Pay attention to the following points:

- Transport and / or store the device in the unopened original packaging.
- Protect the device from harmful physical influences including dust, heat and humidity.
- Do not damage connections through mechanical or thermal impact. Prior to installation inspect the actuator for transport damages. Do not install damaged actuators

## Configuration / Commissioning

In the event of abnormal behavior (including change of operating conditions), the device must be shut down immediately. Installation and commissioning must only be carried out by adequately trained and authorised personnel. After correct assembly and commissioning, the device is ready for operation.

## Maintenance / Repair

Switch-off the power supply to the equipment before carrying out any operation. Maintenance must be performed only by trained and authorized people.

Do not open or modify the Indicator case. Tampering with this product can compromise the correctness and accuracy of its function. In the event of a malfunction, do not attempt to repair the unit.

## Disposal and Recycling

The device's electronic components contain materials that are harmful for the environment and are carriers of recyclable materials at the same time; therefore, the product must be disposed of, separating electronics and batteries, at designated collection points according to local laws and regulations, to ensure proper recycling and environmental protection.

*Only for EU countries:* the crossed-out wheeled bin symbol indicates that the product and batteries must be collected separately from household waste. Defective or used batteries must be recycled according to Regulation (EU) 2023/1542. Return the product to an authorized WEEE collection facility).

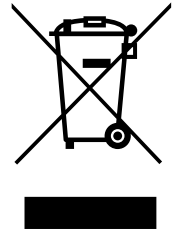

*Battery:* This device contains a battery that can be removed and replaced by the user. The battery should be removed from the product before disposal.

- Do not use short-circuit, disassemble, damaged or leaking batteries; in case of leakage, avoid contact with skin and eyes.
- Do not expose the batteries to heat sources, fire, or direct sunlight.
- Do not throw batteries into fire or water.
- Keep batteries out of reach of children.

## 1.1 Cybersecurity

The Directive 2014/53/EU is not applicable to this device because it is not a Radio Equipment and cannot communicate with any other device.

## 2 Product release information

This manual specifically refers to devices updated to **Firmware Release 7.0.x** or later (please refer to chap. 12.7). Some menu items may not be described as they relate to functionalities that are additional, experimental or reserved for special use. In case of specific need, it is recommended to ask the ELESa support for assistance. ELESa reserves the right, without further communication, to make improvements, additions, corrections to the menu items that do not modify or affect the described functionality of the product but are necessary for the continuous improvement to which these products are subjected.

## 3 Description

The Elesa DD51-E position indicators, referred hereafter as Indicator, are designed to show on its display the position of a machine component moved by a shaft which is connected to the device by means of its pass-through bushing. For convenient use, no cable is needed thanks to internal battery power supply.

A typical use case in industrial automation is a Format Changeover System: mounted on an endless screw shaft, the Indicator can be configured, by means of parameters, to display the conveyor measure. Another use is to indicate the position of machine's element driven by an endless screw connected to the device.

**NOTE:** *this device is not a measure instruments so periodic calibrations are not mandatory.*

### 3.1 Working principle

The Indicator works reading the TURNS of its bushing, that is connected to machine's shaft. This drives the element of the machine whose POSITION must be tracked. The following simplified formula explains how the Indicator calculates the displayed position:

$$\text{POSITION} = (+/-)\text{TURNS} \times \text{STEP} + \text{ORIGIN} + \text{OFFSET}$$

- **+/- DIRECTION**  
The first step is to set in which direction the shaft rotation increases the element position; it is possible to configure this parameter in the menu "**dir**".
- **STEP**  
The second step is to define the element position variation value (in Unit of Measure) that correspond to each turn of the shaft: it is possible to configure this parameter in the menu "**StEP**".
- **ORIGIN**  
When the indicator is switched-on, that shaft position is take as **Internal Reference Point** or, in other words, the point where the absolute position is "**0.0**". Very often, it does not correspond to the real ZERO position of the machine element, so it is possible to align them:
  - setting a new ORIGIN configuring the difference value in the menu "**OrG**"
  - Zero the **Internal Reference Point**.
- **OFFSET**  
During the normal machine operation, the position of components may change due to setup modifications, such as replacing tools or devices. The Indicator allows you to compensate these changes by configuring and recalling up 10 offset values through the "**OFFS**" menu. By default, is used the "**OFFS 0**" and is set to "**0.0**", enabling quick adjustments for any setup variation without losing measurement accuracy.

For parameters and configurations info, please refer to **Programming Mode** for details (chap. 10).

**WARNING:** *the parameters of the ORIGIN and OFFSETs for INCH are linked (not independent) to the MM and NO\_UNIT by the appropriate conversion coefficient. In the case of DEGREES and 0-360DEG, these parameters are totally different and independent from the previous ones.*

The Indicator can work in three different modes:

- **Operating Mode:** it is the default mode. On the display, it is reported the calculated position.
- **Programming Mode:** it refers to how to configure the different parameters present in the menu.
- **Target Mode:** it refers to a mode that helps to reach one of the 32 recallable position memories available.

### 3.2 “Format change” use case example

A typical application of the Indicators is in the Format Change mechanism in Packaging Automated Lines. The device is used to indicate the width of the conveyors belt guides where the cardboard box passes; the guides are adjusted via rotation of a threaded shaft, to which the device is mounted. After the installation, the best practice is to space the guide by a known distance, then zero the **Internal Reference Point** and set the ORIGIN as the value known distance; then set the correct DIRECTION and set the STEP parameter to match the pitch of the threaded axle. Target Memories allow preset specific cardboard box widths, enabling quick recall for future runs. Additionally, if different guide types are used, the OFFSET feature manages the variations in guide thickness.

### 3.3 “Tube cutting machine” use case example

A tube cutting machine is another common application for the Indicator. The device measures the position to stop the tube and determine its length. While the end-stop is fixed, it doesn't always align with the tube's zero length, so setting the ORIGIN compensates for this discrepancy. Additionally, the machine may use different blades depending on the material being cut, each with varying thickness. The OFFSET feature handles these blade thickness variations; so the Indicator can store up to 10 different values, for up to 10 blades in this example.

## 4 Mechanical and electrical characteristics

Power supply	Lithium battery CR2450 3.0 V
Battery life	Up to 3 years <sup>(1)</sup>
Display	5-digit LCD of 8 mm height and special characters
Reading scale	-19999; 99999
Number of decimal digits	Up to 3 digits (configurable)
Unit of Measure	mm, inches, degrees, deg360 <sup>(2)</sup> , no_unit <sup>(3)</sup> (configurable)
Rotation max. speed	300/600/1000 r.p.m. <sup>(4)</sup> (configurable)
Resolution	10.000 impulses/revolution
Protection level	IP65 or IP67 (not UL evaluated)
Working temperature	0°C ÷ +50°C
Storage temperature	-20°C ÷ +60°C
Relative humidity	Max. 95% a 25° C without condensation
Environment	Indoor use
Altitude	Up to 2000 m
Certification	CE, FCC, UKCA, ( UL <sup>(5)</sup> )

(1) Battery life depends on the conditions of use (setup, temperature, ...). The indication is an estimation made in temperature conditions >20 °C and <30 °C and default setup. Furthermore, this refers to the condition of the device when it leaves the ELESA factory. Long storage times must always be considered for the estimation of the battery life when the device becomes operational.

(2) “deg360” manage the angular movement only as it is a single rotation instead multiple rotation

(3) “no\_unit” the values are not referred to any specific Units of Measure; no symbols are showed on the display

(4) Default: 600 r.p.m.

(5) The UL certification is only present in a specific product series with “-AE-V0” in the code description

## 5 Installation

- Drill a  $\varnothing 6 \times 10$  mm hole in the machine frame with a 22 mm center distance from the shaft to fit the rear referring pin.
- unpack the Indicator and unscrew the grub screw in the bushing.
- If necessary, to absorb the slightest misalignments of the shaft, apply the gasket supplied with the device: remove the protective film and apply it to the back side of the Indicator; if not, remove the rear gasket.
- Fit the indicator onto the spindle and make sure that the referring pin fit the hole.

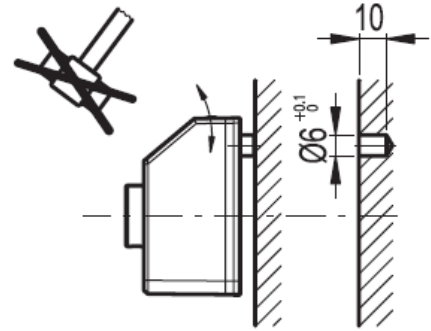

**WARNING: do not force or hit the device to mount it! It may result in permanent damage.**

- Clamp the boss to the spindle by tightening the grub screw with hexagon socket and cup end, according to UNI 5929-85.

### WARNING:

- especially for IP67 version the bushing seems to be hard to rotate: this is due to initial gasket friction that will be reduced with use.
- The Indicator has been designed measure the rotary movement of the shaft and not to withstand excessive mechanical stress. It is suggested to check that the shaft has adequate mechanical supports to avoid weighing on the device, to limit shaft eccentricity, bending, to avoid excessive vibrations.

## 6 User Interface

The user can interact with the Indicator through its display and control keys.

### 6.1 Display

The display is a 5-digit LCD display. The view orientation can be reversed to better fit the Indicator's mounting configuration: please refer to chap. 10.1 to "**diSPL**".

There is also the **ECO Mode** option that allows you to turn-off the display after inactivity: please refer to chap. 12.8.

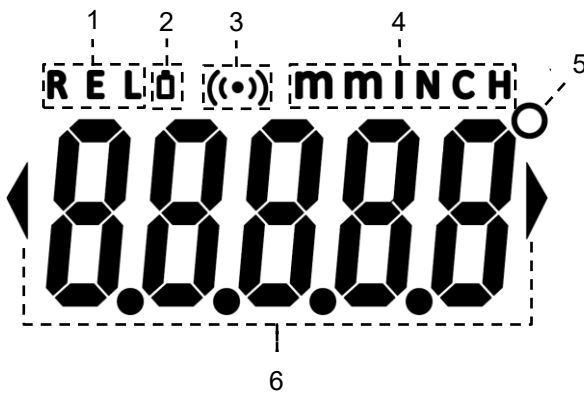

Symbols (or icons):





1. RELATIVE method selected
2. Low battery level
3. Radiofrequency Connection (only RF version)
4. Linear Unit of Measure: MM, INCH
5. Angular Unit of Measure: DEGREES (not-blinking) or DEG360 (blinking)
6. Target direction indicators

## 6.2 Keys

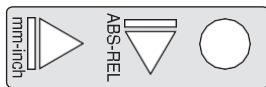
The keys use, or combination of them, depends by the working mode:

- in **Operating Mode**, they allow a quick access to special functions (single or keys combination, short or long press)
- in **Programming Mode**, they allow to move between the menus and set the working parameters
- in **Target Mode** they allow a quick access to special function (single or keys combination, short or long press)



Keys	Programming Mode (temporary)	Operating Mode (default)	Target Mode (temporary)
	<p>While the menu selection, confirm the item displayed.</p> <p>While choosing a parameter, confirm the current selection.</p> <p>While inserting the value of a parameter, it confirms the set value.</p>	<p>The use of this key is to enter in <b>Programming Mode</b>: press the key down for 4 seconds to go.</p>	<p>The long-press of this key go to "<b>StoPt</b>" menu and if confirmed with another press, exit and return in <b>Operating Mode</b>.</p> <p>In the menu "<b>o _ _ _ o</b>" it is possible to change this key working in <b>Target Mode</b> (refer to chap. 10.1).</p>
	<p>While the menu selection, exit and return to <b>Operating Mode</b>.</p> <p>While the value insertion:</p> <ul style="list-style-type: none"> <li>• Short-press: the digit's value increase</li> <li>• Long-press: the digit's value decrease</li> </ul>	<p>The default use of this key is to select between ABSOLUTE or RELATIVE mode: please refer to chap. 9.2.</p> <p>In the menu "<b>_ _ o _ _</b>" it is possible to change this key working (refer to chap. 10.1).</p>	None
	<p>While the menu selection:</p> <ul style="list-style-type: none"> <li>• Short-press: go to next menu item</li> <li>• Long-press: go to previous menu item</li> </ul> <p>While the value insertion:</p> <ul style="list-style-type: none"> <li>• Short-press: select the right digit</li> <li>• Long-press: cancel the value insertion</li> </ul>	<p>The default use of this key is to select the Unit of Measure: please refer to chap. 9.1.</p> <p>In the menu "<b>o _ _ _ _</b>" it is possible to change this key working (refer to chap. 10.1).</p>	None
	None	<p>The default use of this keys' combination is to go directly to "<b>OrG</b>" menu to set the ORIGIN parameter: please refer to chap. 9.6.</p> <p>In the menu "<b>o _ _ _ o</b>" it is possible to change this key working (refer to chap. 10.1).</p>	None

Keys	Programming Mode (temporary)	Operating Mode (default)	Target Mode (temporary)
	None	<p>The default use of this keys' combination is to go directly to "<b>OFS 0</b>" menu to select the OFFSET to be used: please refer to chap. 9.6.</p> <p>In the menu "<b>_ _ o _ o</b>" it is possible to change this key working (refer to chap. 10.1)</p>	None

**Note:** the words: increase, decrease, up and down, refer to the direction of the arrow in the default configuration; by changing the orientation of the display, the meaning of the keys is reversed accordingly.

## 7 Quick Guide



To help the user to become familiar with the indicator, below is a quick guide for initial use:

1. Unpack the Indicator.
2. Switch-on the Indicator (refer to chap. 8).
3. Check initial display test: all the segments should be turned-on.
4. Enter the **Programming Mode** and **Restore Factory Setting** (refer to chap. 12.2).
5. Wait the end of **Start-Up** sequence.
6. Select the desired Unit of Measure (refer to chap. 9.2).
7. Enter the **Programming Mode** and configure the desired RESOLUTION, which is the number of decimal digits to be shown on the display (refer to chap. 9.3).
8. Enter in **Programming Mode** and configure the desired DIRECTION, which is the shaft rotation direction that increases the position (refer to chap. 10).
9. Configure the desired STEP, which is the number of Unit of Measure corresponding to a single shaft rotation (refer to chap. 10.1)
10. Exit from the Programming Mode (refer to chap. 6.2 or 10) and check that the “**Store**” message on the display.
11. Try to turn the shaft by hand and check that the position changes of the correct Unit of Measure.
12. Install the device on the system’s shaft (refer to chap. 5).
13. Set the machine’s element, that its position should be measured by Indicator, in its reference position
14. Enter in **Programming Mode** and set the desired value that should be shown on the display by the Indicator at this element’s position, in the ORIGIN parameter (refer to chap. 10).
15. Zeroing the internal Reference Point (refer to chap. 12.1).
16. Moving the machine’s element and verifying the Indicator behavior is as required.

Further details and features are described in the rest of the manual.

## 8 To switch-on the device (Start-Up)

The Indicator is provided by ELESAswitched-off (display-off) but with battery already mounted; after read and understand the “Safety Instructions” (refer to chap. 1), it is possible to proceed to switch-on the Indicator:

- hold down the  key while pressing the  key.
- the **Start-Up** sequence begins with showing some device’s information. The display will:
  - turn-on all segments (display test)
  - shows “**ELESA**” (manufacturer)
  - shows “**dd51E**” (device model)
  - shows “**no rF**” (no RF device)
  - shows “**r7.0.xx**” (Firmware Release): “xx”= minor revision that could change without notice
  - shows “**00100**” (example of Device ID lower part)
- the actual position is set as zero (**0.0**) as **Internal Reference Point**
- at the end the Indicator enters the default **Operating Mode**: now the Indicator is ready to use.

**WARNING:** when the device is switched-on, especially after a long period of storage, it is possible that some segments of the display remain abnormally lit during the startup phase. The phenomenon is transitory and does not affect the correct operation and use of the device as it will disappear in a short time.

## 9 Operating Mode

After the **Start-Up** sequence, the device enters the **Operating Mode** and shows on the display the current position. With the keys, it is possible to change the visualization settings or directly access to special configuration menu (as a shortcut).

### 9.1 Unit of Measure

The Indicator allows you to manage five different Units of Measure that can be grouped into 3 sets:

<b>Unit of Measure</b>	<b>Description</b>	<b>Display Symbols</b>	<b>Note</b>
<i>Linear (nOdEG)</i>	<i>useful when shaft moves the machine's element that performs a linear motion</i>		
<b>"MM"</b>	International System length unit (millimeters)	<b>"mm"</b>	with its own specific parameters
<b>"INCH"</b>	Imperial length unit (inches)	<b>"inch"</b>	Linked (not independent) to millimeters by the appropriate conversion coefficient; it shares all the parameters with it
<i>Angular (OndEG)</i>	<i>useful when shaft moves the machine's element that performs a rotary movement</i>		
<b>"DEGREES"</b>	Plane angle unit that can manage more than one rotation (>360°)	" ° " no-blinking	with its own specific parameters
<b>"DEG360"</b>	Plane angle unit that works as only a single rotation	" ° " blinking	it shares all the parameters with DEGREES
<i>No metrics (nOnE)</i>	<i>useful when no Unit of Measure is requested or is not relevant</i>		
<b>"NO_UNIT"</b>	No Unit of Measure is shown on the display	none	shares the same parameters as millimeters

The only way to select the Unit of Measure is using the  key in **Operating Mode** and is available as default: with the menu "**o** \_ \_ \_" it is possible to change the key behavior and furthermore setting to "**OFF**" is possible to avoid accidental change (refer to chap. 10.1).

## 9.2 Measure Method: Absolute or Relative selection



The current position can be shown on the display in two different Measure Method:

Measure Method	Symbol	Description	Example
ABSOLUTE ( <b>ABS</b> ) [DEFAULT]	None	The display shows the current position starting from <b>Internal Reference Point</b> (zero at the <b>Start-Up</b> ) In case of "DEG360" of Unit of Measure the position's range changes become: <b>0° ÷ 359.99°</b>	7
RELATIVE ( <b>REL</b> )	"REL"	The device shows the distance related to a <b>Relative Reference</b> position, set up by the user when pressing the  key (*). In case of "DEG360" Unit of Measure the position's range changes become: <b>-179.99° ÷ 180.00°</b>	7 - 4 = 3

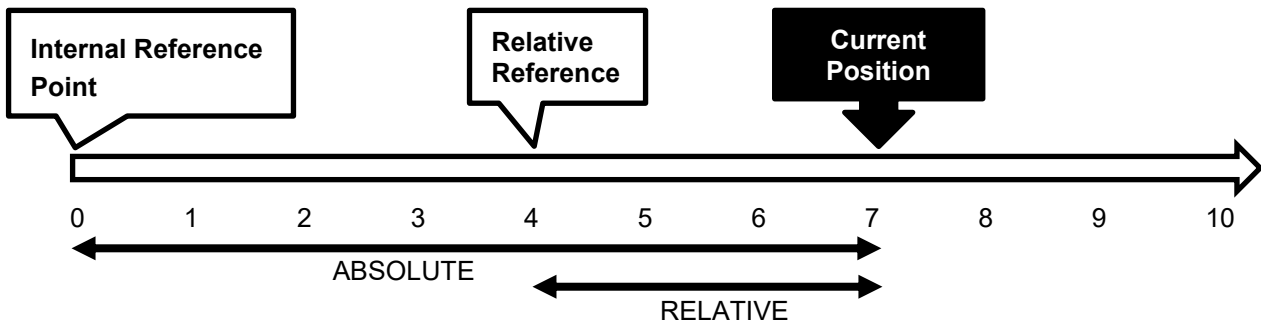
The only way to select the Measure Method is by pressing the  key in **Operating Mode** and is available as default: with the menu "   **o**   " it is possible to change the key behavior and furthermore setting to "**OFF**" is possible to avoid accidental change (refer to chap. 10.1).





(\*) The **Relative Reference** is set in the following ways:

- [DEFAULT] when changing from ABSOLUTE to RELATIVE pressing the  key: the menu "   **o**   " must be set to "**ArCLr**" (refer to chap. 10.1)
- when the  +  keys' combination is pressed: the menu "   **o**   " must be set to "**Ar**" (refer to chap. 10.1)

## 9.3 Display Resolution

The position is shown on the display with different RESOLUTION (number of decimal digit) for each of the Units of Measure; to change it:

- ensure to have selected the correct Unit of Measure
- enter in the **Programming Mode**
- select the “**rES**” menu
- the actual RESOLUTION for the actual Unit of Measure is shown
- press the  key to select between the available RESOLUTION for the actual Unit of Measure
- press the  key to confirm and exit returning in **Operating Mode**
- from now on, the position displayed at selected Unit of Measure is shown with the selected number of decimals: e.g. if is selected the “**0.1**”, the position will be displayed with a single decimal digit “**1234.5**”





**Note:** each Unit of Measure has its own independent RESOLUTION value!

To make the most of the device's indication capacity, in **Operating Mode** the RESOLUTION is automatically reduced if the position to be displayed exceeds the capacity of the display: in this case the last digit of the position on the display will blink, and the RESOLUTION variation is temporary (it is restored if the display is able to display the position) and has no effect on the set parameters (refer to chap. 14).

**WARNING:** some parameters are hardly related to RESOLUTION (such as ORIGIN, OFFSETs and TARGETs): if the RESOLUTION of one Units of Measure changes, to avoid setting errors, all these parameters are reset; therefore, it is advisable to decide and set the display RESOLUTION of all Units of Measure as a first step in device's installation.

## 9.4 OFFSET selection

By default, the Indicator use as OFFSET the “**OFS 0**” with its default value “**0.0**” (refer to chap. 3.1); is possible to select other OFFSETs already configured directly in **Operating Mode**:



- press the  +  keys' combination: the menu “**\_ \_ o \_ o**” must be set to “**L OFS**” (refer to chap. 10.1)
- the menu “**OFS 0**” will be displayed
- press the  key to select the desired OFFSET, already configured (refer to chap. 10), from the list
- press the  key to confirm the selection and return to **Operating Mode**
- from now on, the current position is added to the desired OFFSET

If no, wait or press the  key to exit and return to **Operating Mode** without selecting the new OFFSET.

It is possible to change or disable this keys' combination, via menu “**\_ \_ o \_ o**”: please refer to chap. 10.1.

## 9.5 Quick Zeroing of the Internal Reference Point

It is possible to reset the **Internal Reference Point** (correspond to zero it as at the **Start-Up**) directly in **Operating Mode** (not as default):



- press the  +  keys' combination: the menu “**\_ \_ o \_ o**” must be set to “**SEtOr**” (refer to chap. 10.1)
- the menu “**SEtOr**” will be displayed
- press the  key to confirm to zero and the device return to **Operating Mode**: if the current OFFSET is zero, the current position will be “**0.0**”

If no, wait or press the  key to exit and return to **Operating Mode** without zero.

It is possible to change or disable this keys' combination, via menu “**\_ \_ o \_ o**”: please refer to chap. 10.1.

## 9.6 Quick setting of ORIGIN, OFFSET values and STEP

It is possible to configure some parameters, ORIGIN, OFFSETs and STEP, directly in **Operating Mode**:

- press the  +  keys' combination
- depending by the menu "**o \_ \_ \_ o**" the specific menu will be displayed:
  - "**OrG**" menu to configure the ORIGIN parameter [DEFAULT]: if selected "**P\_OrG**"
  - "**StEP**" menu to configure the STEP parameter: if selected "**P\_Stp**"
  - "**OFS 0**" menu to configure the OFFSET parameters: if selected "**P\_OFS**"
- press the  key to confirm the parameter value and the device return to **Operating Mode** using the new value of the parameter.

If no, wait or press the  key to exit and return to **Operating Mode** without setting the new parameter.

It is possible to change or disable this keys' combination, via menu "**o \_ \_ \_ o**": please refer to chap. 10.1.









## 10 Programming Mode

The **Programming Mode** allows, through a menu tree (refer to chap. 10.2), to configure all the parameters; to enter the **Programming Mode**, while in the **Operating Mode**, keep the  key pressed for 5 seconds: on the display, the “**Foo**” message starts to compose and, at the end, it will be shown the first parameter of the menu “**dir**”.

**WARNING:** it is possible to protect the access to the menu with a password; in this case instead the first menu “**dir**” is shown the insertion menu “**00000**” with a blinking cursor. With the keys is possible to insert the 5-digit password and access to **Programming Mode**; if the inserted password is not correct, the “**ErrOr**” message appears. Please refer to chap. 12.8.

To scroll through the menu or submenu list, press the  key and select the desired item by pressing the  key; as soon as in the selected item, if it is present a parameter, the stored value is displayed.

According to the type of item selected, it is possible to:

- select a parameter value from a list (e.s. “**dir**”, “**SPEED**”):
  - press the  key to scroll between the available options
  - press the  key to confirm the desired option: if it is different from the stored value, the display will show the message “**CHAnG**”; otherwise, if it is equal, the display will show the message “**CAnCL**”. In both cases return to the previous menu (except when changing the “**rES**” or “**diSPL**” menu that returns directly in **Operating Mode**)
  - press the  key return to previous menu without saving the changes
- insert a numerical value (e.g. “**OrG**”): once entered, the leftmost digit is selected (blink) and if is useful is shown the Unit of Measure icon:
  - press  key to INCREASE the value of selected (blinking) digit: after “**9**” goes to “**0**” and the digit on the left increments by one unit
  - press and hold  key to DECREASE the value of selected (blinked) digit: after “**0**” goes to “**9**” and the digit on the right decrements by one unit. If the parameter can assume negative values, continuing to decrement after zero will appear “**-**” to indicate a negative value
  - press the  key to select (blink) the next right digit to be changed (up to rightmost and then return to leftmost)
  - press and hold the  key to return to the previous menu without saving.
  - press the  key to accept the value: if it is different from the stored value, the display will show the message “**CHAnG**”; otherwise, if it is equal, the display will show the message “**CAnCL**”. In both cases return to the previous menu
- view only an info value (e.g. “**InFO**”)

In every menu page, after 30 seconds of inactivity, the device will automatically return to **Operating Mode** (refer to chap. 9).



**WARNING:** at the exit and return in **Operating Mode** if one or more parameters values has been changed, their values have been stored: if the operation was successful, the display will show the message “**StorE**”.



**WARNING:** when setting the parameters, the bushing must be locked in the current position, otherwise there is the possibility of obtaining a not valid position once you exit the **Programming Mode**. If this is not possible, it is recommended to check the device setting once back in **Operating Mode**.







## 10.1 Parameters/Menus (in alphabetical order)

To adapt the Indicator to the specific use, it is possible to set many parameters: most are configurable in **Programming Mode**, others selectable via specific key function

**WARNING:** typically, each menu allows you to set a parameter, so they are often indicated with the same word.

Parameter	Menu/Key	Description	Available options	Default
Measmode		Change the Measure Method between ABSOLUTE and RELATIVE: key use defined in “_ _ 0 _ _” menu.	Please refer to chap. 10.2. <ul style="list-style-type: none"> <li>• “ABS” → ABSOLUTE</li> <li>• “REL” → RELATIVE</li> </ul>	“ABS”
Units		Change the Unit of Measure: key use defined in “0 _ _ _ _” menu.	Please refer to chap. 10.1. <ul style="list-style-type: none"> <li>• MM → “mm” symbol</li> <li>• INCHES → “inch” symbol</li> <li>• DEGREES → “°” no-blink</li> <li>• DEG360 → “°” blinking</li> <li>• NO_UNIT → no symbols</li> </ul>	“MM”
DIRECTION count_direction	“dir”	Position increase Direction: sets the positive rotation direction of the shaft.	<ul style="list-style-type: none"> <li>• “- - 0” anti clock-wise</li> <li>• “0 - -” clock-wise</li> </ul>	“- - 0”
display	“diSPL”	Display view orientation	<ul style="list-style-type: none"> <li>• “0°” → the boss hole is horizontal</li> <li>• “180°” → the boss hole is vertical</li> </ul>	“180°”
OFFSET offset_mm offset_deg	“OFFS”	List of Offset values: configure the values that can be added to current position to adapt to the various machine’s set-up.	It is possible to configure up to 10 Offsets value: “OFS 0” ... “OFS 9” The values range depends on the RESOLUTION set as follows: <ul style="list-style-type: none"> <li>• Res = “1” -19999 ÷ 99999</li> <li>• Res = “0.1” -1999.9 ÷ 9999.9</li> <li>• Res = “0.01” -199.99 ÷ 999.99</li> <li>• Res = “0.001” -19.999 ÷ 99.999</li> </ul>	“0.0”
ORIGIN mm_origin deg_origin	“OrG”	Origin value: values that can be added to current position to redefine the absolute ZERO position.	The values range depends on the RESOLUTION set as follows: <ul style="list-style-type: none"> <li>• Res = “1” -19999 ÷ 99999</li> <li>• Res = “0.1” -1999.9 ÷ 9999.9</li> <li>• Res = “0.01” -199.99 ÷ 999.99</li> <li>• Res = “0.001” -19.999 ÷ 99.999</li> </ul>	“0.0”
PTOLL mm_toll deg_toll	“PtoLL”	Tolerance to enter the Target Position acceptable range.	The values range depend on the Unit of Measure in use: <ul style="list-style-type: none"> <li>• MM, NO_UNIT: 0.03 ÷ 999.99</li> <li>• INCH: 0.001 ÷ 39.370</li> <li>• DEGREES, DEG360: 0.01 ÷ 999.99</li> </ul>	MM or NO_UNIT: “0.10” INCH: “0.004” DEGREES or DEG360: “0.10”
RESOLUTION mm_res	“rES”	Display Resolution: number of decimal	The selectable values depend on the Unit of Measure in use: <ul style="list-style-type: none"> <li>• MM, NO_UNIT: 1; 0.1; 0.01</li> </ul>	MM or NO_UNIT: “0.01”

Parameter	Menu/Key	Description	Available options	Default
inch_res deg_res		digits shown on the display.	<ul style="list-style-type: none"> <li>• <b>INCH:</b> 1; 0.1; 0.01; 0.001</li> <li>• <b>DEGREES, DEG360:</b> 1; 0.1; 0.01</li> </ul> An independent RESOLUTION value is stored for each group of Unit of Measure.	INCH: "0.001" DEGREES or DEG360: "0.01"
SPEED speed	" <b>SPEED</b> "	Maximum allowed shaft speed rotation (rpm)	<ul style="list-style-type: none"> <li>• "300"</li> <li>• "600"</li> <li>• "1000"</li> </ul>	"600"
STEP mm_step deg_step	" <b>STEP</b> "	Conversion coefficient between the number of shaft rotations and the selected Unit of Measure.	The values range depend on the Unit of Measure in use: <ul style="list-style-type: none"> <li>• <b>MM, NO_UNIT:</b> 0.03 ÷ 999.99</li> <li>• <b>INCH:</b> 0.001 ÷ 39.370</li> <li>• <b>DEGREES, DEG360:</b> 0.01 ÷ 999.99</li> </ul> The values for MM and NO_UNIT are linked (not independent) to INCH by the appropriate conversion coefficient; for DEGREES and DEG360 are independent.	MM or NO_UNIT: "1.00" INCH: "0.039" DEGREES or DEG360: "1.00"
TARGET target_mm target_deg	" <b>tArGE</b> "	List of Target Memories: user configured target positions. Once loaded (activated) with one of them, the Indicator enters the <b>Target Mode</b> and helps the user to reach it.	It is possible to configure up to 32 target positions: ".tG00"... ".tG31" The values range depends on the RESOLUTION set as follows: <ul style="list-style-type: none"> <li>• <b>Res = 1</b> -19999 ÷ 99999</li> <li>• <b>Res = 0.1</b> -1999.9 ÷ 9999.9</li> <li>• <b>Res = 0.01</b> -199.99 ÷ 999.99</li> <li>• <b>Res = 0.001</b> -19.999 ÷ 99.999</li> </ul>	"0.0"
ukey_reg	"o _ _ _ _"	In <b>Operating Mode</b> , it defines the action of  key press.	<ul style="list-style-type: none"> <li>• "<b>ALL</b>": it is possible to select between all the units: MM, INCH, DEEGRES, DEG360 and NO_UNIT.</li> <li>• "<b>nOdEG</b>": available only if the actual Unit of Measure is MM or INCH and allows to select only between them.</li> <li>• "<b>OnDEG</b>": available only if the actual Unit of Measure is DEEGRES or DEG360 and allows to select only between them.</li> <li>• "<b>nOnE</b>": available only if the actual Unit of Measure is NO_UNIT and no changes are allowed.</li> <li>• "<b>OFF</b>": the key action is disabled</li> </ul>	"ALL"
arkey_reg	"_ _ o _ _"	In <b>Operating Mode</b> , it defines the action of  key press.	<ul style="list-style-type: none"> <li>• "<b>ArCLr</b>": each key pressing allows the change between ABS and REL mode: when changing from ABS to REL the <b>Relative Reference</b> is set.</li> <li>• "<b>Ar</b>": each key pressing allows the change between ABS and REL mode: when changing from ABS to REL the <b>Relative Reference</b> is NOT update.</li> <li>• "<b>OFF</b>": the key action is disabled</li> </ul>	"ArCLr"

Parameter	Menu/Key	Description	Available options	Default
orkey_reg	"----o"	It defines how the display works in <b>Target Mode</b> : accordingly defines the action of  key press.	<ul style="list-style-type: none"> <li>• "<b>dtArG</b>": the display shows the current absolute position. By pressing the  key, the Target Position to be reached will be displayed.</li> <li>• "<b>dtoGO</b>": the display blinks showing the distance from the current position to the Target Position to be reached. By pressing the  key, the current absolute position will be displayed.</li> <li>• "<b>OFF</b>": the display shows the current absolute position. The key action is disabled.</li> </ul>	"dtoGO"
ukey_shift_reg	"o---o"	In <b>Operating Mode</b> , it defines the action of the  +  keys' combination press.	<ul style="list-style-type: none"> <li>• "<b>P_OrG</b>": go directly to "<b>OrG</b>" menu to set the ORIGIN parameter.</li> <li>• "<b>P_Stp</b>": go directly to "<b>StEP</b>" menu to set the STEP parameter.</li> <li>• "<b>P_OFS</b>": go directly to "<b>OFS 0</b>" menu to set the OFFSET parameters.</li> <li>• "<b>OFF</b>": the keys' combination action is disabled.</li> </ul>	"P_OrG"
arkey_shift_reg	"_o_o"	In <b>Operating Mode</b> , it defines the action of the  +  keys' combination press.	<ul style="list-style-type: none"> <li>• "<b>L OFS</b>": go directly to "<b>OFS 0</b>" menu to select the OFFSET to be used</li> <li>• "<b>SEtOr</b>": go directly to "<b>SEtOr</b>" menu to reset the <b>Internal Reference Point</b> (as at the <b>Start-Up</b>).</li> <li>• "<b>OFF</b>": the keys' combination action is disabled.</li> </ul>	"L OFS"
password passw	"PASS"	To enable/disable/set the password to access to <b>Programming Mode</b> .	<ul style="list-style-type: none"> <li>• "<b>OFF</b>": password disabled, no restriction to access to <b>Programming Mode</b></li> <li>• "<b>on</b>": password enabled: to access to <b>Programming Mode</b> it is necessary to insert the 5-digit password</li> <li>• "<b>SEt</b>": to set or change the 5-digit password</li> </ul>	"OFF"
eco_mode_time	"ECO"	To enable/disable the <b>ECO Mode</b> to turn-off the display in <b>Operating Mode</b> when there is no activity.	<ul style="list-style-type: none"> <li>• "<b>dtout</b>": number of seconds of inactivity (<b>000 ÷ 255</b>) before turn-off the display. To disable this function and keep the display always on, set "<b>000</b>"</li> </ul>	"000"

## 10.2 Menu tree

1 <sup>st</sup> Level	2 <sup>nd</sup> Level	Options
"dir"		"- - o" [DEFAULT] "o - -"
"OrG"	-	-19999 ÷ 99999* 0.0 [DEFAULT]
"OFFS"	"OFS 0" [DEFAULT]	-19999 ÷ 99999* 0.0 [DEFAULT]
	...	
	"OFS 9"	
"StEP"		MM, NO_UNIT: 0.03 ÷ 999.99 1.00 [DEFAULT]
		INCH: 0.001 ÷ 39.370 0.039 [DEFAULT]
		DEGREES, DEG360: 0.01 ÷ 999.99 1.00 [DEFAULT]
"rES"		MM, NO_UNIT: 1, 0.1, 0.01 0.01 [DEFAULT]
		INCH: 1, 0.1, 0.01, 0.001 0.001 [DEFAULT]
		DEGREES, DEG360: 1, 0.1, 0.01 0.01 [DEFAULT]
"diSPL"		"0°"
		"180°" [DEFAULT]
"SPEED"		"300"
		"600" [DEFAULT]
		"1000"
"PtoLL"		MM, NO_UNIT: 0.03 ÷ 999.99 0.10 [DEFAULT]
		INCH: 0.001 ÷ 39.370 0.004 [DEFAULT]
		DEGREES, DEG360: 0.01 ÷ 999.99 0.10 [DEFAULT]
"tArGE"	"LOADt"	"LtG00"
		...
		"LtG031"
	"PrOGt"	"PtG00"
"o _ _ _ _"		...
		"PtG31"
		-19999 ÷ 99999* 0.0 [DEFAULT]
"o _ _ _ _"		"ALL" [DEFAULT]
		"nOdEG" (only if the actual Unit is MM or INCH)
		"OnDEG" (only if actual Unit is DEGREES or DEG360)
		"nOnE" (only if actual Unit is NO_UNIT)
		"OFF"
"_ _ o _ _"		"ARClr" [DEFAULT]
		"Ar"
		"OFF"
"_ _ _ _ o"		"dtArG"
		"dtoGO" [DEFAULT]
		"OFF"

Scrolling menu direction

	<b>"o _ _ _ o"</b>		<b>"P_OrG"</b> [DEFAULT] <b>"P_StP"</b> <b>"P_OFS"</b> <b>"OFF"</b>	
	<b>"_ _ o _ o"</b>		<b>"L OFS"</b> [DEFAULT] <b>"SEtOr"</b> <b>"OFF"</b>	
	<b>"PASS"</b>		<b>"OFF"</b> [DEFAULT] <b>"on"</b> (see chap. 12.8) <b>"SEt"</b> (see chap. 12.8)	
	<b>"LcdtS"</b>		(see chap. 12.5)	
	<b>"PbtSt"</b>	<b>"_ _ _ _ _"</b>	(see chap. 12.6)	
	<b>"ECO"</b>	<b>"dtout"</b>	<b>0 ÷ 255</b> (see chap. 12.9)	<b>000</b> [DEFAULT]
	<b>"rESEt"</b>		<b>"no"</b> <b>"OrG"</b> (see chap. 12.1) <b>"ALL"</b> (see chap. 12.2) <b>"ALLOF"</b> (see chap. 12.3) <b>"OFF"</b> (see chap. 12.4)	
<b>"InFO"</b>		<b>"rEL"</b> (see chap. 12.7) <b>"dAtE"</b> (see chap. 12.7) <b>"SEr"</b> (see chap. 12.7) <b>"rbYtE"</b> (see chap. 12.7)		

\* The values must be divided by the number of decimal places of the RESOLUTION set.



# 11 Targets Mode

If you use frequently the same destination positions, the Indicator helps you to manage them with the **Target Mode**: selecting one of the 32 Target Memories, desired Target Positions, the device suggests the direction of rotation of the shaft to reach it. To use this function, first is to configure the Target Memories, then is to load (activate) one of them to enter in **Target Mode** and its help.

**WARNING:** while in **Target Mode**, it is not possible to use the functions accessible with keys in **Operating Mode**: e.g. change the Unit of Measure, Measure Method or enter if **Programming Mode**.





## 11.1 Configure a Target Memory

To use the **Target Mode** is necessary to configure at least one Target Memory:

- enter in the **Programming Mode**
- select the "**TArGE**" menu
- select the "**PrOGt**" sub-menu
- press the  key to scroll between Targets Memories to be programmed: from "**PtG00**" to "**PtG31**"
- press the  key to select the Target Memory
- insert the position value of the Target Memory: please refer to chap. 10 for the value insertion
- press the  key to confirm the value and return to preceding menu; from now it is possible to select it as Target Position



## 11.2 Load (activate) a Target Memory as Target Position

After setting, to enter in **Target Mode** is necessary to load(activate) a selected Target Memory to set it as desired Target Position:

- enter in the **Programming Mode**
- select the "**TArGE**" menu
- select the "**LOADt**" sub-menu
- press the  key to scroll between Targets Memories to be loaded(activated): from "**LtG00**" to "**LtG31**"
- press the  key to confirm the selected Target Memory: on the display are shown the "**◀**" "**▶**" symbols and the position of Target Memory to be reached
- press the  key to confirm and enter in **Target Mode**: the display will show the message "**StorE**". Or press the  key to cancel and return to preceding menu

## 11.3 Display and key working in Target Mode

In **Target Mode**, to help to reach the Target Position, the display can work in three different ways, defined in menu "**\_\_\_o**": please refer to chap. 10.1.

- **TO\_GO**: as default, if is out of the Target Position, the display blinks indicating the distance from the current position to the Target Position to be reached; instead, if is in the Target Position the display, not blinking, indicate the current absolute position: the menu "**\_\_\_o**" must be set to "**dtoGO**". In this case, pressing the  key, the current absolute position will be displayed.
- **TO\_TARGET**: the display shows the current absolute position; to understand to be out of the Target Position only the blinking "**◀**", "**▶**" symbols on the display is present: the menu "**\_\_\_o**" must be set to "**dtArG**". In this case, pressing the  key, the Target Position to be reached will be displayed.
- **OFF**: the display shows the current absolute position (like the preceding) but the  key pressing has no action; the menu "**\_\_\_o**" must be set to "**OFF**".

**WARNING:** in case of "**DEG360**" Unit of Measure, the display shows values only with range: **-179.99° ÷ 180.00°**

## 11.4 Indications for reaching the Target Position

In **Target Mode**, through the “◀”, “▶” symbols on the display, the Indicator suggests to the user the direction of rotation of the shaft to reach the Target Position.

Through the “**PtoLL**” parameter is possible to set an acceptable range around the desired Target Position (refer to chap. 10).

The TARGET has been reached when the difference between the selected Target Position, (=T) and the current position (=M) is less than “**PtoLL**” parameter (=Toll) in absolute value.

Case	Shaft	“dir” = “- - ◯”	“dir” = “◯ - -”	Note
$M < (T - \text{Toll})$	Stationary or moving	◀ (blinking)	▶ (blinking)	Outside the Target range
$(T - \text{Toll}) \leq M < T$	For about 4 sec	◀	▶	Entering in Target tolerance
$(T - \text{Toll}) \leq M < (T + \text{Toll})$	Stationary	◀ + ▶	◀ + ▶	Target reached
$T < M \leq (T + \text{Toll})$	For about 4 sec	▶	◀	Entering in Target tolerance
$M > (T + \text{Toll})$	Stationary or moving	▶ (blinking)	◀ (blinking)	Outside the Target range

Legend:

T = Target Position loaded (activated)



M = current position

Toll = tolerance (see “**PtoLL**” parameter)

**WARNING:** the Target Position and its tolerance parameters for INCH Units of Measure are linked (not independent) to MM and NO\_UNIT by the appropriate conversion coefficient and are stored together. In the case of DEGREES, these parameters are totally different and independent of the previous ones.

## 11.5 Disabling the Target Mode



From the **Target Mode**, it is possible to exit only by following steps below:

- press and hold down the  key for 3sec
- the display will show the “**StoPt**” message
- press the  key to confirm: the device exits and return to **Operating Mode**; or press  key to cancel

## 12 Additional functions



### 12.1 Zeroing of the Internal Reference Point

To reset the **Internal Reference Point** (as zero at the **Start-Up**):

- enter in the **Programming Mode**
- select the “**rESEt**” menu
- press the  key to scroll until select the “**Org**” sub-menu
- press the  key to confirm: the display will show the message “**StorE**”
- the device exits and returns to **Operating Mode**: if the current OFFSET and ORIGIN values are zero, the current position will be “**0.0**”



### 12.2 Restore Factory settings

To restore the Indicator to factory state (all the parameters are restored to original value):

- enter in the **Programming Mode**
- select the “**rESEt**” menu
- press the  key to scroll until select the “**ALL**” sub-menu
- press the  key to confirm: all parameters will be set to factory default
- the device will reset, the device begins the **Start-Up** sequence



### 12.3 Restore Factory settings and switch-off the device

To restore the Indicator to factory state (all the parameters are restored to original value) and switch-off the device:

- enter in the **Programming Mode**
- select the “**rESEt**” menu
- press the  key to scroll until select the “**ALLOF**” sub-menu
- press the  key to confirm: all parameters will be set to factory default
- the display will turn-off and the device enter switch-off mode (very low consumption as exit from ELESA)



### 12.4 Switching-off the device (for storage only)

To switch-off the device:

- enter in the **Programming Mode**
- select the “**rESEt**” menu
- press the  key to scroll until select the “**OFF**” sub-menu
- press the  key to confirm
- the display will turn-off and the device enter switch-off mode (very low consumption as exit from ELESA)

### 12.5 LCD test





To verify the correct working of the LCD display, all segments can be turned-on:

- enter in the **Programming Mode**
- select the “**LCdtS**” menu
- press the  key to confirm: all the segments of the display will turn-on
- press the  key to return to “**LCdtS**” menu and then exit

**WARNING:** without the  key pressing, the device remains indefinitely in this state!



## 12.6 Keys test

It is possible to verify the correct functioning of each key individually:

- enter in the **Programming Mode**
- select the “**PbtSt**” menu
- press the  key to confirm: the display will show “- - - -”
- pressing each key will be show a “0” at relative display position:
  - press the  key: the display will show “0 - - - -”
  - press the  key: the display will show “- - 0 - -”
  - press the  key: the display will show “- - - - 0”
- the only way to return to **Operating Mode** is to wait 30 seconds without pressing any keys



## 12.7 Device info

It is possible to read some specific info about the device: this is helpful for better support from ELESa service.



- enter in the **Programming Mode**
- select the “**InFO**” menu (if there is not the “InFO” menu, the Firmware Release is antecedent the 7.0.0)
- press the  key to scroll the items and press the  key to view the specific value:
  - “**rEL**” → Firmware Release: e.g. “**r7.0.00**”: a variation of the last two digit has no impact on the device’s features and performance
  - “**dAtE**” → Firmware Release date: e.g. “**01-25**”
  - “**SEr**” → Device ID lower part: e.g. “**12345**”
  - “**rbYtE**” → reset error code

## 12.8 Password: Parameters modification locking



It is possible to restrict access to **Programming Mode**, to avoid changing parameters, enabling password protection:

- enter in the **Programming Mode**
- select the “**PASS**” menu
- press the  key to scroll until select the “**SEt**” sub-menu
- press the  key to confirm: the default password “**22011**” is shown
- change the 5-digit password with your new one.

**WARNING: please take note of the new password to avoid losing it!**

- press the  key to confirm the value: if has been changed, the display will show the message “**CHAnG**”
- using the  key to scroll until select the “**on**” sub-menu: the display will show the message “**CHAnG**”
- exit and return to **Operating Mode**: from now on, the next time to access will be necessary to insert the 5-digit password

To remove the password protection, disabling it:



- enter in the **Programming Mode** inserting the 5-digit password
- select the “**PASS**” menu
- press the  key to scroll until select the “**OFF**” sub-menu
- press the  key to confirm
- exit and return to **Operating Mode**. The next time access will be free

Please note that to restrict the access also to keys’ combinations is not enough to enable the password, but has necessary to disable the keys’ combination: in the **Programming Mode** set the corresponding menu to “**OFF**”

## 12.9 ECO Mode: auto turn-off the display



It is possible to configure the Indicator to turn-off the display after a certain time of inactivity: this is useful to reduce battery consumption.

To enable this function:

- enter in the **Programming Mode**
- select the “**ECO**” menu
- press the  key to enter in “**dtout**” parameters sub-menu
- set the number of seconds of inactivity to turn-off the display: if remain “**000**” this function remains disable and the display always remain on (as default)
- press the  key to confirm: if has been changed, the display will show the message “**CHAnG**”
- exit and return in from **Operating Mode**
- From now on, in **Operating Mode** and **Target Mode** (when the desired Target Position has to be reached) after the configured number of seconds of inactivity, the display will turn-off, but the Indicator continues to read the bushing rotation; while the display is off the following event will turn-on it:
  - Any keys pressing
  - Any bushing movementIn **Target Mode** when the current position is in not acceptable range around the desired Target Position, the display will remain turned-on.

## 12.10 Speed limits setting

It is possible to configure the maximum shaft rotation speed: a rotation speed higher than 600 rpm can only be maintained for short periods of time. A lower maximum speed value increases the battery life.

- enter in the **Programming Mode**
- select the “**SPEED**” menu
- press the  key to select between the available speeds
- press the  key to confirm: if has been changed, the display will show the message “**CHAnG**”
- exit and return in from **Operating Mode**: from now on, if the speed exceeds to set maximum, the “**S\_Err**” message is shown (refer to chap. 14).

## 13 Battery replacement

The Indicator is powered by an internal lithium battery CR2450 - 3.0V initially supplied with the device by ELESa. Its status is continuously checked: when the  symbol appears on the display the battery must be replaced as soon as possible. To replace the battery without losing the position, the Indicator can work without it for some seconds. Please follow the next instruction:

- is not necessary to remove the indicator from the drive shaft
- unscrew the two TORX T6 screws of the battery cover: put the cover and the screws in a safety place
- keep ready the new battery
- check the correct battery position (to copy it for next insertion): negative pole is towards the bushing
- very quickly remove the battery from its compartment (better using a magnet or in worst case tweezers) and insert the new battery: the display must always remain on.





**Note:**

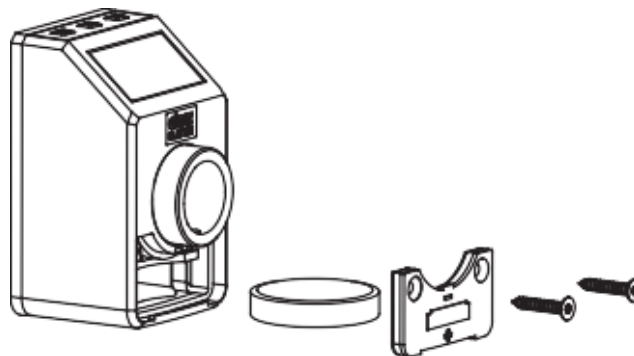



- if the display remains off, it is possible that the battery is reversed, please check battery position
- if the switch-on sequence starts the initial position and the configuration must be checked
- re-insert the battery cover and close it with the two TORX T6 screws
- disposal the removed battery following as described in the previous “Safety Instruction” chapter

**WARNING: be careful when reassembling the battery cover; IP protection rating may degrade and water, moisture and dust may enter in the device and damage it.**



## 14 Display messages and troubleshooting

<i>Event / Display</i>	<i>Description</i>	<i>Action</i>
Last digit (the rightmost) of Position/value is blinking	The number cannot be shown on the display at selected RESOLUTION: a reduction has been applied.	In <b>Operating Mode</b> , the device continues to indicate the current position of the shaft, but the value is outside the capacity of the display and selected RESOLUTION: the message shows the bushing direction that generates the overflow.  To exit from overflow and return to view the position, please rotate in opposite direction or correct some parameters.
“o ----” or “---- o”	This is the next step following the previous event: the value cannot be displayed, and a RESOLUTION reduction has been already applied. The value exceeds the capacity of the display: <b>(-19999 ÷ 99999)</b>	If you are viewing a parameter, the problem may be due to the difference in Units of Measure between when it was set and when it is displayed. Change the current Unit of Measure and try again to view the parameter. Attempting to change a parameter when the display shows the overflow, automatically returns the parameter to the first value that can be displayed, losing the initial setting.
Value blinking with “◀” or “▶” symbols	<b>Target Mode</b> active with the menu “_ _ _ o _ _” must be set to “ <b>dtoGO</b> ” or “ <b>OFF</b> ”: the display blinks the distance from the current position to the Target Position to be reached and is bigger than the tolerance: please refer to chap. 11.4.	Please refer to chap. 11.4.
Value with both “◀” and “▶” symbols	<b>Target Mode</b> active and the Target Position has been reached.	Please refer to chap. 11.4.
“S_Err” message	The shaft rotation speed has exceeded the maximum allowed.	Press the  key to exit and return to <b>Operating Mode</b> : the device will almost certainly have lost the <b>Internal Reference Point</b> and must be re-set correctly. It should also be evaluated whether it is possible to increase the value of the “ <b>SPEED</b> ” parameter.
“SEnEr” message	The encoder sensor reading error.	Press the  key to try to exit and return to <b>Operating Mode</b> : the device will almost certainly have lost the <b>Internal Reference Point</b> and must be re-set correctly. If it remains in error, the device is in fail: press  key and then  key to turn-off it and then contact ELESa support.

<b>Event / Display</b>	<b>Description</b>	<b>Action</b>
<p><b>"ErFLA"</b> Temporary message</p>	<p>A flash memory writing of a parameter has failed.</p>	<p>Please repeat the programming and then contact ELESA support.</p>
<p><b>"E - - - -"</b> or <b>"- - E - -"</b> or <b>"- - - - E"</b></p>	<p>At the <b>Start-Up</b>, the key test found a key pressed</p>	<p>Verify no keys are pressed by the user or other; wait some seconds and the device will continue the <b>Start-Up</b> sequence.  If not, please contact ELESA support.</p>
<p><b>"00000"</b> instead <b>"dir"</b></p>	<p>The Password is enabled and must be inserted to enter in <b>Programming mode</b></p>	<p>Insert the 5-digit password</p>
<p>Display off</p>	<p>If enabled, the device is entered in ECO mode after inactivity.</p>	<p>Press any key to turn-on the display: please refer to chap. 12.8.</p>
<p>Display off</p>	<p>The device is switched-off</p>	<p>Switch it on: please refer to chap. 8.</p>
<p>Pressing the  key does not change the Unit of Measure</p>	<p>The menu "<b>o _ _ _ _</b>" is set to <b>"OFF"</b></p>	<p>Enter in <b>Programming Mode</b> and change the key behavior in menu "<b>o _ _ _ _</b>".</p>
<p>Pressing the  key do not change the Measure Method</p>	<p>The menu "<b>_ _ o _ _</b>" is set to <b>"OFF"</b></p>	<p>Enter in <b>Programming Mode</b> and change the key behavior in menu "<b>_ _ o _ _</b>".</p>
<p>Lost Password</p>	<p>The Password is enabled and is no longer the default</p>	<p>Contact ELESA support.</p>
<p> Blinking battery symbol</p>	<p>Low Battery</p>	<p>Replace the battery as soon as possible: please refer to chap. 13.</p>
<p> Battery symbol</p>	<p>Very Low Battery</p>	<p>Replace the battery as soon as possible: please refer to chap. 13.</p>

## 15 CE Declaration of Conformity (DoC)



### EU DECLARATION OF CONFORMITY (DoC)

**WE as manufacturer:**  
*NOI COME FABBRICANTE:*

COMPANY NAME / NOME FABBRICANTE : Elesa S.p.a.  
POSTAL ADDRESS / INDIRIZZO DI POSTA : Via Pompei 29  
POSTCODE AND CITY / CITTA : 20900 Monza (Italy)  
TELEPHONE NUMBER / NUMERO TELEFONO : +39 039 28111  
E-MAIL ADDRESS / INDIRIZZO DI POSTA : [info@elesa.com](mailto:info@elesa.com)

**Declare that this DoC is issued under our sole responsibility and belongs to the following product:**  
*DICHIARA CHE LA PRESENTE DoC È RILASCIATA SOTTO LA NOSTRA ESCLUSIVA RESPONSABILITÀ E SI RIFERISCE AL SEGUENTE PRODOTTO:*

PRODUCT / PRODOTTO : Electronic position Indicators / Indicatori di posizione elettronici  
APPARATUS MODEL / MODELLO : DD51-E  
TRADE MARK / MARCA COMMERCIALE : Elesa

**The object of this DoC described above is in conformity with the relevant Union harmonization legislation:**  
*L'OGGETTO DELLA DoC DI CUI SOPRA È CONFORME ALLA PERTINENTI NORMATIVE ARMONIZZATE DELL'UNIONE EUROPEA:*

- 2014/30/EU (EMC) Electromagnetic Compatibility Directive
- 2011/65/UE (RoHS) Restriction of the use of certain Hazardous Substances in electrical and electronic equipment

**The following harmonized standards and technical specifications have been applied:**  
*DI SEGUITO LE NORME ARMONIZZATE E RIFERIMENTI AD ALTRE SPECIFICHE TECNICHE UTILIZZATE:*

- EN 61326-1:2021

**Notified Body:**

*ORGANISMO NOTIFICATO:*  
Not Involved (Annex II - Conformity Assessment Module A)  
*NON COINVOLTO (ALLEGATO II - MODULO A DI VALUTAZIONE DELLA CONFORMITÀ)*

**Additional information:**  
*INFORMAZIONI AGGIUNTIVE:*

-

PLACE, DATE OF ISSUE: Monza – Italy  
*LUOGO, DATA EMISSIONE* 01/10/2025

CARLO BERTANI  
MANAGING DIRECTOR - GENERAL MANAGER

## 16 UKCA Declaration of Conformity (DoC)



### UKCA DECLARATION OF CONFORMITY (DoC)

*IN ACCORDANCE WITH UK GOVERNMENT GUIDANCE*

**WE as manufacturer (2.):**

*NOI COME FABBRICANTE:*

COMPANY NAME / *NOME FABBRICANTE* : Elesa S.p.a.  
POSTAL ADDRESS / *INDIRIZZO DI POSTA* : Via Pompei 29  
POSTCODE AND CITY / *CITTÀ* : 20900 Monza (Italy)  
TELEPHONE NUMBER / *NUMERO TELEFONO* : +39 039 28111  
E-MAIL ADDRESS / *INDIRIZZO DI POSTA* : [info@elesa.com](mailto:info@elesa.com)

**Declare that this DoC is issued under our sole responsibility and belongs to the following product (1. , 3.):**

*DICHIARA CHE LA PRESENTE DoC È RILASCIATA SOTTO LA NOSTRA ESCLUSIVA RESPONSABILITÀ E SI RIFERISCE AL SEGUENTE PRODOTTO:*

PRODUCT / *PRODOTTO* : Electronic position Indicators / *Indicatori di posizione elettronici*  
APPARATUS MODEL / *MODELLO* : DD51-E  
TRADE MARK / *MARCA COMMERCIALE* : Elesa

**The object of this DoC described above is in conformity with relevant UK Statutory Instruments and their amendments (4.):**

*L'OGGETTO DELLA DoC DI CUI SOPRA È CONFORME ALLA PERTINENTE NORMATIVA UK STATUTORY INSTRUMENTS E RELATIVE MODIFICHE:*

- 2014/30/EU(EMC) Electromagnetic Compatibility Directive
- 2011/65/UE (RoHS) Restriction of the use of certain Hazardous Substances in electrical and electronic equipment

**The following harmonized standards and technical specifications have been applied (5.):**

*DI SEGUITO LE NORME ARMONIZZATE E RIFERIMENTI AD ALTRE SPECIFICHE TECNICHE UTILIZZATE:*

- EN 61326-1:2021

**Notified Body (6.):**

*ORGANISMO NOTIFICATO:*

Not Involved (Annex II - Conformity Assessment Module A)

*NON COINVOLTO (ALLEGATO II - MODULO A DI VALUTAZIONE DELLA CONFORMITÀ)*

**Additional information:**

*INFORMAZIONI AGGIUNTIVE:*

-

PLACE, DATE OF ISSUE:  
*LUOGO, DATA EMISSIONE*

Monza – Italy  
01/10/2025

CARLO BERTINI  
MANAGING DIRECTOR - GENERAL MANAGER

## 17 FCC Supplier's Declaration of Conformity (SDoC)



# FEDERAL COMMUNICATION COMMISSION SUPPLIER'S DECLARATION OF CONFORMITY (SDoC)

**WE as manufacturer:**

*NOI COME FABBRICANTE:*

COMPANY NAME / *NOME FABBRICANTE* : Elesa S.p.a.  
POSTAL ADDRESS / *INDIRIZZO DI POSTA* : Via Pompei 29  
POSTCODE AND CITY / *CITTA* : 20900 Monza (Italy)  
TELEPHONE NUMBER / *NUMERO TELEFONO* : +39 039 28111  
E-MAIL ADDRESS / *INDIRIZZO DI POSTA* : [info@elesa.com](mailto:info@elesa.com)

**Declare that this SDoC is issued under our sole responsibility and belongs to the following product:**

*DICHIARA CHE LA PRESENTE SDoC È RILASCIATA SOTTO LA NOSTRA ESCLUSIVA RESPONSABILITÀ E SI RIFERISCE AL SEGUENTE PRODOTTO:*

PRODUCT / *PRODOTTO* : Electronic position Indicators / *Indicatori di posizione elettronici*  
APPARATUS MODEL / *MODELLO* : DD51-E  
TRADE MARK / *MARCA COMMERCIALE* : Elesa

**The object of this SDoC described above complies with the following applicable FCC rules and regulations:**

*L'OGGETTO DELLA SDoC DI CUI SOPRA È CONFORME ALLA PERTINENTE NORMATIVA FCC E RELATIVE MODIFICHE:*

- Code of Federal Regulations (CFR) no. 47 Part 15 Subpart B

**Operation is subject to the following two conditions:**

*IL FUNZIONAMENTO È VINCOLATO ALLE DUE CONDIZIONI SEGUENTI:*

- This device may not cause harmful interference, and  
*IL DISPOSITIVO NON CAUSA INTERFERENZE DANNOSE E*
- This device must accept any interference received, including interference that may cause undesired operation.  
*IL DISPOSITIVO PUÒ SUBIRE INTERFERENZE, INCLUSE QUELLE CHE POTREBBERO CAUSARE UN FUNZIONAMENTO INDESIDERATO DEL DISPOSITIVO*

**Test Report Number:**

*NUMERO RAPPORTO DI PROVA:*

- AR25-0115188-01

PLACE, DATE OF ISSUE:  
*LUOGO, DATA EMISSIONE:*

Monza – Italy  
01/10/2025

CARLO BERTANI  
MANAGING DIRECTOR - GENERAL MANAGER

## Elesa S.p.A., Monza, April 2026

The texts and examples have been written with great care, nonetheless, mistakes can always happen. The Company Elesa S.p.A. can neither be held legally responsible nor liable for lacking or incorrect information and the ensuing consequences. The Company Elesa S.p.A. reserves the right to alter or improve the electronic position indicators or parts of them and/or the enclosed brochures without prior notice.



**ELESA S.p.A.**  
Via Pompei, 29  
20900 Monza (MB) Italy  
phone +39 039 28111  
[info@elesa.com](mailto:info@elesa.com)  
[www.elesa.com](http://www.elesa.com)

© COPYRIGHT ELESA 2026  
Art. Nr. DDEMAN-006-04en